

THE WEST AFRICAN EXAMINATIONS COUNCIL,

ACCRA.



**BASIC EDUCATION CERTIFICATE
EXAMINATION**

**REGULATION, SCHEMES
OF EXAMINATION
AND
SAMPLE QUESTIONS**

TABLE OF CONTENTS

<u>ITEM</u>	<u>PAGE</u>
Introduction	
General Information to Candidates	
Rules and Regulations on Malpractice	
Syllabus Outlines and Specimen Questions.. .. .	
Preamble	
English Language	
French	
Ghanaian Languages	
Social Studies	
Religious and Moral Education	
Integrated Science.. .. .	
Mathematics	
Basic Design and Technology	
Information and Communication Technology	

INTRODUCTION

This booklet contains the Rules and Regulations, Syllabus topics, Schemes of Examination and Sample Questions for the subjects offered at the Basic Education Certificate Examination (BECE) in Ghana. This information is meant to guide teachers and candidates preparing for the examination. The Section on the syllabuses contains only lists of major topics to be covered, so teachers and candidates are advised to consult the teaching syllabuses developed by the Ghana Education Service (GES) to thoroughly acquaint themselves with the scope and depth of material to be covered.

**GENERAL INFORMATION TO CANDIDATES FOR THE BASIC EDUCATION
CERTIFICATE EXAMINATION**

1. NAME OF EXAMINATION

With effect from 2015 two examinations will be conducted in a year; one for School Candidates and the other for Private Candidates, and named:

- (1) Basic Education Certificate Examination for School Candidates (preceded by year of examination);
- (2) Basic Education Certificate Examination for Private Candidates (preceded by year of examination);

Thus the examinations to be conducted in 2015 would be known as *2015 Basic Education Certificate Examination for School Candidates* and *2015 Basic Education Certificate Examination for Private Candidates*.

2. ELIGIBILITY

(1) School Candidates

The BECE for school candidates will be administered exclusively to school candidates at the end of the third year in any junior high school recognised by the Ministry of Education. It is expected that the candidate should have undergone at least nine years of basic education.

(2) Private Candidates

Two categories of private candidates are permitted to register for the examination.

(1) Re-Sit Candidates

This consists of candidates who have previously sat for BECE. Candidates are therefore required to provide their index numbers and the year they sat for the examination previously.

(2) First Time Candidates

These are candidates who are 18 years or above. Candidates will be required to supply their date of birth during the registration.

3. REGISTRATION FOR THE EXAMINATIONS

(1) General Directions

- (i) Registration will be done electronically as prescribed by the Council.
- (ii) Candidates are expected to register in accordance with the guidelines and instructions for the examinations issued by the Council.
- (iii) It is the responsibility of the Heads of School (for BECE School Candidates) and the Private Candidate to ensure the accuracy of entry data such as names, age and subject options. They should also ensure that the appropriate fees are paid. The Council shall not take responsibility for any error, oversight, or default committed by them.

WAEC WILL NOT TAKE RESPONSIBILITY FOR ANY WRONG DATA ENTERED.

- (iv) The Council does not undertake to refund fees. However, when entries are rejected or cancelled, the Council may refund any fees paid in full or in part after deduction of administrative expenses.
- (v) Registration should be completed and all documents forwarded to the Council not later than the deadlines specified by it.
- (vi) The Council reserves the right to reject entries which do not satisfy the instruction, guidelines and regulations of the examination and/or are not accompanied by the appropriate fees.

(vii) The Council reserves the right to nullify any entry at any stage before the examination if it is found to be irregular.

(2) School Candidates

School candidates are expected to be registered by schools duly recognised by the Ministry of Education. The candidates should be bonafide students of the Junior High Schools registering them.

The Council reserves the right to ensure that schools have adequate facilities for the conduct of the examination.

(3) Private Candidates

Private candidates are to register individually within the period specified by Council.

Facilities for BECE for Private Candidates will be provided by the Council.

(4) Directions to Candidates

“Directions to Candidates” will be made available online at the time of floating of entries for the examination.

4. NULLIFICATION OF REGISTRATION

(1) School Candidates

- (a) Any candidate found to have been registered by a school other than the school he/she attended for the entire duration of Junior High School shall have his/her entry nullified unless the transfer to the school has been approved by the GES.
- (b) Any registered school candidate without genuine continuous assessment scores will be deemed to be ineligible for the examination and have his/her entire or subject entry cancelled. Heads of School should therefore ensure that the continuous assessment scores of all candidates in all subjects are forwarded to the Council as required.

(2) Private Candidates

Any registered candidate shall be deemed to be ineligible for an examination if he/she had

- (a) not taken the BECE for School Candidates previously;
- (b) not attained 18 years before entering as a first-time candidate;
- (c) not completed serving the ban imposed on him/her by the Final

Awards Committee for indulging in examination malpractice in a previous examination.

5. DATE AND TIME TABLE OF EXAMINATION

(1) The dates for the examinations will be communicated to participating schools by circular through the Ghana Education Service and to private candidates by advertisements in the print media.

(2) The examinations Time Table will be issued with the registration documents.

6. CENTRE ARRANGEMENTS

(1) No candidate will be permitted to write the examination at any centre other than the one he/she has been assigned to by the Council.

(2) **The Council reserves the right to re-direct private candidates to other centres if there are not enough entries for any particular centre or if there are more candidates at a centre than can be accommodated there.**

7. FEES

Fees are to be paid at some selected banks as prescribed by the Council.

Note that registration will **not** be valid without the payment of the requisite fee.

8. MATERIALS TO BE PROVIDED BY CANDIDATES

Candidates must provide their own pens, pencils, erasers, mathematical sets and painting materials. They are required to write their answers in **ink; only** blue ink

should be used and pencils may be used **only** for diagrams.

The Council will provide pencils for objective papers.

9. INFECTIOUS DISEASES

Candidates who have been exposed to any infectious disease **cannot** write the examination at any centre unless they are quarantined.

10. ASSESSMENT OF CANDIDATES

(1) Subjects for the Examinations

School candidates are to enter and sit for the number of subjects approved by GES.

(The list of subjects will be issued with the registration documents)

Private Candidates may enter and sit for any number of subjects they wish.

(2) Continuous Assessment Scores

Continuous Assessment scores will be required of school candidates. School based assessment for the first, second and the third years will be required by the Council.

The scores for each year should be recorded and submitted to the Council as specified.

The Heads of School should check and certify the information to be provided. The Continuous Assessment scores should be sent to the Council not later than the end of the second term of the third year of the course.

The Council would not be able to produce results for candidates without their Continuous Assessment scores.

Private candidates are not required to provide Continuous Assessment scores.

(3) Grading of Candidates

Candidates will be graded on a nine point scale as follows:

- 1- Highest
- 2- Higher
- 3- High

- 4- High Average
- 5- Average
- 6- Low Average
- 7- Low
- 8- Lower
- 9- Lowest

11. **ISSUE OF RESULTS AND THE AWARD OF CERTIFICATES**

(1) General Information

- (i) The award of a certificate is entirely within the jurisdiction of the Council. The Council will **not** be liable to any candidate in respect of the withholding or cancellation of any certificate improperly obtained.
- (ii) Certificates issued by the Council remain its property and legal proceedings will be instituted against any person who alters anything on them.

(2) School Candidates

- (i) For school candidates, results sheets will be sent to Heads of School through the Metropolitan/Municipal/District Directors of Education after the release of the results. The results sheets will show the results in the examination as a whole for each school and will also indicate the standard reached in each subject taken by each candidate presented unless the results of the candidate has been withheld or cancelled.
- (ii) The certificates will also be sent to Heads of School through the Metropolitan/Municipal/District Directors of Education.
- (iii) School candidates shall collect their certificates from their schools.

(3) Private Candidates

- (i) Private candidates can access their results from the Council's website with the use of **PIN** sold by the Council and its accredited agents.

(ii) Private candidates shall collect their certificates from the Council's office located in the region in which they took the examination on completing and presenting the Certificate Collection Form accompanied with an approved national identification document.

(4) Request for Re-Marking

Request for remarking should be received **not later than 60 days** after the release of results. Any candidate who makes such a request will pay the appropriate fee before the remarking is done.

(5) Disposal of Examination Scripts

Examination scripts will be disposed of **three (3) months** after the release of results.

12. CANCELLATION OF RESULTS AND CERTIFICATES

- (i) The Council reserves the right to cancel the results of candidates if it is proved that they have been involved in examination irregularities before, during or after the examination.
- (ii) It also reserves the right to recall and cancel certificates of candidates involved in any acts of examination malpractice.
- (iii) The Council will **not** enter into correspondence about results with any school candidate or their parents or guardians or any other person claiming to act in *loco parentis*. All correspondence regarding such issues should be sent to the Council by the schools through the Districts/Metropolitan/Municipal/District Directors of Education.
- (iv) Private candidates are required to forward any complaint about their results to the Council themselves.

13. GUIDELINES FOR ENTRANCE INTO SECOND CYCLE INSTITUTIONS

The criteria for selection of candidates into Senior High School are drawn up by the Ministry of Education. Candidates should therefore contact the Ministry of Education for them.

14. INSTRUCTIONS TO CANDIDATES

- (a) The examination centre shall be under the control of the Supervisor who shall be responsible to the Council for the proper conduct of the examination.
- (b) The Supervisor will be required to carry out the detailed instructions sent to him/her with reference to the conduct of the examination at the centre. These relate to the distribution of examination question papers to candidates, the collection of scripts at the end of each period and their despatch to the Council in accordance with the Council's directives and the maintenance of constant and effective supervision over the candidates.
- (c) It is the duty of the Supervisor in all cases of irregularity or misconduct in the examination to report to the Council. A candidate who is involved in such irregularity or misconduct must be allowed to continue the examination unless he/she interferes with the work of the other candidates. Further action on such candidates will be taken by the Council in accordance with its rules and regulations.
- (d) A candidate whose examination work is affected by adverse circumstances should inform the Supervisor at the centre at which he/she takes the examination before, during or immediately after the examination. In case of sickness he/she must supply the Supervisor with a medical report, which should be forwarded to the Council.
- (e) The Council may, at any time, send a Special Supervisor to a school or centre to take control of the examination, or may send an officer or Inspector to a school or centre

during the examination to ascertain whether the examination is being conducted in strict accordance with the Regulations.

- (f) The Council may, at any time, relocate an examination centre as it may deem fit, before, during or after the examination if there is evidence of massive irregularity and threat to life and property.
- (g) It is the responsibility of the Supervisor to report all cases of irregularity, misconduct or acts which contravene the rules governing the proper conduct of the examination.
- (h) Any candidate who is reported for misconduct or malpractice is expected to write a statement on his/her conduct.
- (i) Candidates must obey all instructions given by the Supervisors and Invigilators. In particular, they must enter and leave the hall when told to do so.
- (j) Candidates must **not** give or receive any assistance in answering the examination questions.
- (k) Candidates must **not** talk to other candidates during the examination.
- (l) Candidates must **not** tear any part of their question papers and objective answer sheets or answer booklets.
- (m) Candidates must stop work when they are told to do so and must always hand over their objective answer sheets or answer booklets to the Supervisors/Invigilators at the end of the examination.
- (n) Candidates should **not** remove any answer booklet or question paper from the examination hall. Examination papers remain the property of the Council and may only be removed if the Supervisor permits it.
- (o) In all cases of irregularity the Council may, after considering the report, cancel either the results of the candidate in the subject involved or his/her entire results.

- (p) Candidates should **not** bring any book, paper, bag, mobile phone or unapproved material into the examination room/hall. Such cases will be punished as prescribed by Rules and Regulations of the examination.
- (q) The Council does **not** accept responsibility for such books, bags, mobile phone or other property which candidates leave at the precincts of the examination centers.
- (r) Candidates may **not** be allowed into the examination hall after thirty (30) minutes of the commencement of the examination.
- (s) Candidates should **not** leave the examination hall within thirty (30) minutes of the commencement of the examination.

15. PHYSICALLY CHALLENGED CANDIDATES

Candidates with the disabilities indicated in the registration document should notify the Council in writing with the appropriate documentation of their condition to enable the Council make special arrangements for them. This notification should reach the Council not later than the last date of the period specified in the registration document.

**THE RULES AND REGULATIONS FOR DEALING WITH CASES OF IRREGULARITY IN
THE COUNCIL'S EXAMINATIONS**

(1) BRINGING FOREIGN MATERIAL INTO EXAMINATION HALL

- 1.1 Where a candidate is found in the examination hall with notes, textbooks, prepared material or any other printed material, the candidate's entire results in the examination shall be withheld pending cancellation of the results of the subject involved by the appropriate Committee of Council.
- 1.2 Where a candidate is found in the examination hall with a blank piece of paper or any other material not covered under 1(1) above, (except mobile phone or any other electronic communication device) the entire results of the candidate shall be withheld pending cancellation of the results of the subject involved by the appropriate Committee of Council.
- 1.3 Where a candidate is found with a programmable calculator in the examination hall, the entire results of the candidate shall be withheld pending cancellation of the results of the subject involved.
- 1.4 Where a candidate is found with a mobile phone or any other electronic communication device in the examination hall, the entire results of the candidate shall be withheld pending the cancellation of his/her entire results by the appropriate Committee of Council.

(2) IRREGULAR ACTIVITIES INSIDE OR OUTSIDE THE EXAMINATION HALL

- 2.1 Where a candidate is apprehended for offence(s) such as those listed below, inside or outside the examination hall, the candidate's entire results in the examination shall be withheld pending cancellation of his/her entire results by the appropriate Committee of Council.
 - (i) Stealing, converting or misappropriating the script(s) of other candidate(s);
 - (ii) Substitution of worked script during or after the examination;
 - (iii) Seeking or receiving help from non-candidate(s) such as invigilator(s), supervisor(s), teacher(s) or other personalities during the examination.
- 2.2 Where the person giving the help is not a candidate for the examination in session, but a prospective candidate, he/she shall be barred from taking any examination conducted by the Council for one year and will also be reported to the appropriate authority for disciplinary action to be taken against him/her. In addition to the above action, the candidate's entire results shall be withheld pending cancellation by the appropriate Committee of Council.
- 2.3 Where a candidate is apprehended for offence(s) such as those listed below inside or outside the examination hall, the candidate's entire results shall be withheld pending cancellation of the results of the subject involved by the appropriate Committee of Council.

- (i) Tearing part of the question paper or answer booklet during the examination;
- (ii) Refusing to submit script to the supervisor after examination;
- (iii) Starting to write an examination before commencement of work is officially announced OR continuing to write after official orders have been given for candidates to stop work;
- (iv) Other irregular activities within immediate precincts of the examination hall before, during or after the examination.

(3) COLLUSION

- 3.1 Where a candidate is caught during the examination passing notes for help from other candidate(s), receiving or giving assistance, talking with or colluding in any manner with another candidate(s) the entire results of the candidate(s) involved shall be withheld pending the cancellation of his/her result(s) for the subject involved by the appropriate Committee of Council.
- 3.2 Where cases of cheating are detected in script(s) and/or otherwise established in one paper, the results of the subject for the candidate(s) involved shall be cancelled.
- 3.3 Where a candidate is proved to have cheated in more than one paper/subject, his/her results in those subjects shall be cancelled.

(4) IMPERSONATION

- 4.0 Where a person is caught impersonating a candidate, he/she shall be handed over to the police for prosecution. The entire results of the person being impersonated and those of the impersonator, if he/she is also a candidate for any WAEC examination, shall be withheld pending cancellation by the appropriate Committee of Council. Both the impersonator and the impersonated shall be barred from taking any examination conducted by the Council for a period of not less than two years.

(5) LEAKAGE

- a. Where a case of leakage is established at a centre, the entire results of the candidates offering the subject(s) involved at the centre shall be withheld
- b. Candidates proved to have been involved in the leakage shall have their entire results cancelled by the appropriate Committee of Council.
- c. Where it is established that the school authorities condoned, connived at, and/or encouraged the leakage, the entire results of the candidates at the centre shall be withheld pending cancellation of the entire results by the appropriate Committee of Council. In addition, the school shall be de-recognised in accordance with Rule 6 below.

(6) MASS CHEATING

- 6.1 Where more than half of the candidates for the subject at a centre are involved in collusion or other forms of examinations malpractice, this shall be regarded as mass cheating.
- 6.2 Where mass cheating in a subject at a centre is established, the entire results of the candidates at the centre shall be withheld pending cancellation of the results of the subject for those confirmed to have cheated.
- 6.3 Where mass cheating has been established, the following shall also apply:
- (i) In case of schools, a report shall be made to the Ministry of Education or the appropriate Board for disciplinary action to be taken against the person(s) responsible and the school shall be de-recognised for a period not less than one year.
 - (ii) In the case of public centres, the Council shall take appropriate action.
- 6.4 A school shall de-recognised for a stated period if
- (i) Mass cheating is established in more than one paper/subject.
 - (ii) The appropriate Committee of Council is satisfied that the school cannot ensure the satisfactory conduct of the Council's examination.
- 6.5 De-recognition implies that
- (i) The school authority can no longer organise or manage the school as a school centre, although the Council or its agent may use the physical facilities of the school for the purpose of the examination.
 - (ii) The school may be allowed to present its students as school candidates, but the conduct of the whole examination (practical and Theory) shall be the responsibility of Council.
- The school concerned shall pay the prescribed extra fees for the supervision and invigilation of the examination before the examination begins.
- 6.6 Notwithstanding items 6(3)(a) and 6(4) above, recognition may be restored upon a written assurance from the administering authority of the school that the necessary requirement has been satisfied. Such assurance shall contain details of measures being taken to ensure the satisfactory conduct of the examination, and those which shall be put in place subject and accepted by the Council. Recognition, however, will only be restored after at least one year of de-recognition.

(7) INSULT/ASSAULT ON SUPERVISORS/INVIGILATORS/INSPECTORS

- (a) Where a candidate insults or assaults a supervisor/invigilator in the lawful performance of his/her duties inside or outside the examination hall or in any other way disturbs the conduct of the examination, the entire results of the candidate shall be withheld pending

cancellation of the entire results by the appropriate Committee of Council. The candidate shall also be barred from taking any examination conducted by the Council for a period not less than two years. In addition, he/she may be handed over to the police for prosecution.

- (b) Where a candidate brings into the examination hall or uses anything including chemical substance with intent to cause injury, temporary or permanent incapacity to any authorised person in the examination hall including other candidates, the results of the candidates shall be withheld pending the cancellation of the entire results by the appropriate Committee of Council. In addition, the candidates shall be barred for a period not less than two years from taking any examination conducted by the Council.
- (c) Contravention of Rule 7(1) and 7(2) shall not preclude legal action being taken against the candidate by the Council or the individual(s) concerned.

(8) CONTRAVENTION OF INSTRUCTIONS TO CANDIDATES

Where a candidate, in contravention of the instructions to candidates, writes with pencil instead of ink or shades with ink instead of pencil, his/her entire results shall be withheld pending cancellation or his/her results for the subject concerned by the appropriate Committee of Council.

(9) NEW CASES

As new cases arise, which are not covered by the above rules, the appropriate Committee of Council shall take necessary action.

(10) REVIEW

These rules shall subject to review as and when necessary.

SYLLABUS TOPICS AND SPECIMEN QUESTIONS

PREAMBLE

The Syllabus topics outlined for each of the subjects in the section have been extracted from the detailed Syllabuses developed for use in Junior High Schools by the Ghana Education Service. Teachers and prospective candidates are therefore advised to thoroughly acquaint themselves with the scope and the depth of materials to be covered, to ensure adequate preparation for the examination.

The Schemes of Examination have been outlined.

For each subject, there will be two Papers, Paper 1 and Paper 2, both of which must be taken. Paper 1 will be an objective test and Paper 2 an essay test.

Paper 1 and 2 will be combined and taken at one sitting. The time duration for the examination is stated for each Paper.

The Schemes of Examination form the basis of the rubrics. Teachers and prospective candidates are advised to acquaint themselves with them as the contravention will lead to loss of marks. The Specimen Questions presented for each subject should also serve as a guide.

ENGLISH LANGUAGE

SYLLABUS TOPICS

Lexis and Structure

- Tenses
- Concord/Agreement
- Conditional Sentence
- Vocabulary e.g. Phrasal Verbs, General Vocabulary
- Passive and Active forms
- Direct and Reported Speech
- Question and Answer Tags
- Phrases and Clauses
- Idiomatic Expressions
- Parts of speech

Literature

- Basic characters/roles
- Themes
- Literary Devices – symbols, imagery etc
- Subject matter
- Setting
- Plot

Essay Writing

- Letters – formal and informal
- narrative/descriptive
- exposition(describing processes)
- speech
- argument/debate
- article
- report
- agenda
- minute writing
- letters to the press

The essay should not be less than 250 words.

Comprehension

Types of Passages

Concepts to be taught

- the use/meaning of certain words and expressions in relation to their context;
- the understanding of the whole or part of the passage.

Types of Passages

- Dialogue or conversation
- Narrative
- Descriptive
- Explanation of a process
- Giving directions or instructions

STRUCTURE AND SCHEME OF EXAMINATION

There will be two papers, Paper 1 and Paper 2, both of which must be taken. The Papers will be combined and taken at one sitting.

Paper 1: This will be an objective test consisting of **two** parts: Part A, Lexis and Structure and Part B, Literature.

Part A will comprise **32** lexis and structure items and Part B, **8** literature questions.

All the **40** questions will have to be answered within forty-five (**45**) minutes for **40** marks.

Paper 2: This will consist of **two** parts. Part A – Essay Writing and Part B – Comprehension Test.

There will be three topics in Part A and candidates will be expected to write on only one. In Part B, there will be one comprehension passage and the candidates will be required to answer all the questions on it.

The paper will last one (**1**) hour and will carry sixty (**60**) marks.

SAMPLE QUESTIONS

PAPER 1: PART A: LEXIS AND STRUCTURE

SECTION A

*From the alternatives lettered A to D, choose the one which **most suitably** completes each sentence.*

1. Mary is a girl.
 - A. beautiful young Nigerian
 - B. young beautiful Nigerian
 - C. young Nigerian beautiful
 - D. Nigerian young beautiful

2. Kojo plays the violin very well,?
 - A. couldn't he
 - B. don't he
 - C. doesn't he
 - D. can't he

SECTION B

*Choose from the alternatives lettered A to D the one which is **nearest in meaning** to the underlined word in **each** sentence.*

1. My celibate friend is happy.
 - A. single
 - B. simple
 - C. busy
 - D. hardworking

2. You look very shagged.
 - A. beautiful
 - B. worried
 - C. tired
 - D. silly

SECTION C

*In each of the following sentences a word or group of words has been underlined. Choose from the alternatives lettered A to D the one that **best explains** the underlined word or group of words.*

1. The students were told to give a good account of themselves.

This means the students were told to

- A. behave well.
 - B. do well.
 - C. work hard.
 - D. learn hard.
2. Her room is in apple-pie order.

This means her room is

- A. untidy.
- B. tidy.
- C. good.
- D. bad

SECTION D

*From the list of words lettered A to D, choose the one which is **most nearly opposite** in meaning to the underlined word in **each** sentence.*

1. My grandmother is a weak centenarian.

- A. troublesome
- B. robust
- C. cheerful
- D. inquisitive

2. When asked about the breakage, Kofi said he was innocent.

- A. surprised
- B. guilty
- C. afraid
- D. absent

PART B

LITERATURE

Read the excerpts below and choose the **correct** answer from the alternatives lettered A to D.

‘Ama was a lioness in the fight’.

1. The literary device used in the above is

- A. personification.
- B. simile.
- C. metaphor.
- D. alliteration.

‘We are three men

With a plea

To be set free now

To move with glee’

2. The rhyme scheme in the verse above is

- A. abcb
- B. acab
- C. aabc
- D. aaba

PAPER TWO

PART A

ESSAY WRITING

Answer **one** question **only** from this section.

1. Write an article for publication in a national newspaper on the topic:

Why bushfires must be avoided.

2. Your uncle wants to visit you in your school. Give him the directions.

3. Describe to your friends the most interesting function you have attended

COMPREHENSION

Read the following passage carefully and answer the questions which follow:

4. One day a poor fisherman went fishing and caught nothing. He was just about to go home when he felt the net suddenly grow heavy. He thought he had caught a large fish. But when he dragged it ashore, he found only a heavy copper pot sealed with lead. He shook it and feeling sure it contained something valuable, he took his knife, cut the top of the lead and turned it upside down. For a moment nothing came out; and then it started to smoke, and this smoke slowly rose right up to the sky like a thick fog. It suddenly turned into a huge genie.

“Bow down”, said the genie, “and let me kill you.”

“Why?” asked the fisherman, “Have you forgotten that I set you free?”

“Yes, but I have sworn to kill you”, said the genie.

“I’m a spirit that rebelled against the Creator and to punish me he shut me up in this copper pot. During the first century of my captivity, I swore to make anyone who freed me rich. During the second century, I swore I would grant him any three things. But after these centuries, in anger, I swore to kill my liberator without mercy.”

“Well, die I must.” said the fisherman, “but swear that you really were in that pot. It is too small to hold even your little finger. Unless I see it, I shall not believe it.”

“See then and believe,” said the genie.

He slowly changed back into smoke and entered the pot. The fisherman immediately put back the lead cover and threw it into the sea.

1. What did the fisherman catch?
 2. Why did the fisherman open the lead pot?
 3. State two things the genie swore to do.
 4. Explain the following expression in your own words: ‘Well, die I must’.
5. For each of the following words, give another word or phrase that means the same and can fit into the passage:
- (i) ashore
 - (ii) valuable
 - (iii) genie

FRENCH

SYLLABUS TOPICS

Structural Items

Idiomatic expressions and other fixed expressions such as “venir de + infinitif, avoir + faim/soif/âge, combien de + le pluriel” etc.

Vocabulary

- Professions
- Parts of the body
- Days of the week/ months of the year/ time & date
- Parts of building
- Games/hobbies
- Means of transport
- Clothing
- The weather
- Sports
- Geographical places

Comprehension

Should indicate Types of Passages and Concepts to be taught.

Grammar

- Verbs;
- Tenses
- Le présent
- Le future
- Le passé
- L'imparfait

Subject/verb agreement.

- Pronouns
- Adjectives
- Adverbs
- Articles
- Preposition
- Negations
- Gender

Essay – Guided Essay-writing

Emphasis on:

- | | | | |
|---|--------------------|---|----------|
| • | Content | – | 20 marks |
| • | Grammar | – | 10 marks |
| • | Overall Expression | – | 5 marks |
| • | Clarity | – | 5 marks |

NB: As much as possible the essay should be communication-oriented, for example, writing post cards, letters, news items (“faits divers”).

STRUCTURE AND SCHEME OF THE EXAMINATION

There will be two Papers, Paper 1 and Paper 2, both of which must be taken. The Papers will be combined and taken at one sitting.

Paper 1

The Paper will consist of 40 multiple choice objective questions covering lexis, structure and comprehension, all of which must be answered in one hour for 40 marks.

Paper 2

The Paper will consist of two guided essays and candidates will be required to answer **one**. The questions may require picture description, letter writing, narration or description. The paper shall last 45 minutes and carry 40 marks.

SAMPLE QUESTIONS

PAPER 1 - 1hour (40 marks)

Part I - Structural Items

*Below are sentences with blank spaces, followed by options lettered A- D. Choose from the options the **correct** answer that will fit into each blank space and shade on your answer sheet the letter of your choice.*

1. Kofi est en train de ----- son devoir.

- | | |
|----|---------|
| A. | fait |
| B. | faire |
| C. | fais |
| D. | faisant |

2. Mon frère -----quinze ans.
 - A. est
 - B. a
 - C. es
 - D. as

3. Maman vient ----- finir le repas du soir.
 - A. de
 - B. à
 - C. en
 - D. sans

4. Clifford arrive à l'école en ----- .
 - A. à courir
 - B. courant
 - C. courez
 - D. courons

5. Tu as combien ----- grandes sœurs ?
 - A. des
 - B. de
 - C. du
 - D. de la

Part II (Lexical Items)

1. La fille de ma sœur est ma -----
2. Un manguiier produit des -----
3. Le ----- de français apprend aux élèves à chanter des chansons françaises.
4. Hier, notre équipe de football a battu Notre-Dame JSS par deux ----- à zéro.
5. Tous les ----- de cette école ont réussi à l'examen.

	A	B	C	D
1.	sœur	petite fille	nie \square ce	cousine
2.	pommes	oranges	mangues	citrons
3.	directeur	professeur	chanteur	musicien
4.	ballons	baskets	bâtons	buts
5.	candidats	professeurs	ouvriers	gens

Part III (Written Comprehension)

Read the passage below and answer the questions that follow.

La Re \square cre \square ation

Quelle joie pour nous quand la cloche sonne la re \square cre \square ation! Enfin, nous pouvons sortir de la classe. Nous avons tellement faim que nous courons vite en direction de la cantine ou \square se trouvent des vendeuses de fruits : il y a des bananes, des oranges et des mangues. On peut aussi y acheter des biscuits.

Si nous avons soif nous achetons des boissons fraîches : *Fanta*, ou *Coca Cola*.

Apr \square s avoir mangé et bu nous retrouvons les camarades pour jouer à notre jeu favori, *ampe \square* .

Toutes les filles ghane \square ennes savent jouer *ampe \square* . On peut y jouer a \square deux ou plus. Les filles comptent les points tout en sautant en l'air et en frappant dans les deux mains. La premie \square re personne a \square compter dix points a gagne \square . Peu a \square peu, le nombre de joueurs diminue. Le jeu devient le plus inte \square ressant quand il ne reste que deux filles.

La re \square cre \square ation, c'est aussi le moment ou \square les professeurs se reposent. Ils se regroupent dans la salle des professeurs pour bavarder un peu.

Quinze minutes plus tard, la cloche sonne encore une fois et chacun rentre dans sa classe pour reprendre les cours.

1. Pourquoi est-ce que les élèves sont contents quand la cloche sonne ?

Parce qu'ils.....

- A. vont rentrer chez eux.
- B. n'aiment pas les cours.
- C. s'aiment.
- D. n'aiment pas étudier.

2. D'habitude, quelle sorte de nourriture achement-ils ?

Ils achement

- A. des fruits.
- B. des bonbons.
- C. des gâteaux.
- D. du riz.

3. Quel est le jeu favori des filles ?

- A. le football.
- B. l'ampè.
- C. la course.
- D. la promenade.

4. Quelle est la nature du jeu d'ampè ?

Le jeu se caractérise par les

- A. frappes des mains seulement.
- B. sauts en l'air seulement.
- C. frappes des mains et les sauts en l'air.
- D. coups des pieds.

5. Que font les enseignants pendant la récréation ?

- A. Ils corrigent les exercices des élèves.
- B. Ils discutent en se reposant.
- C. Ils boivent des boissons fraîches.
- D. Ils surveillent les jeux des élèves.

6. La re  re  ation dure
- A. 5 minutes.
- B. 10 minutes.
- C. un quart d'heure.
- D. une demi-heure.

Part IV (Grammatical Items and Linkers)

The passage below has ten blank spaces, followed by options lettered A – D. Choose from the options the correct answer that will fit into each blank space and shade on your answer sheet the letter of your choice.

Le Petit Nicholas

Je m'.....1.....Nicholas. J'.....2.....quatorze ans. Je3..... e  le  ve. Je4.....du Ghana, et je suis donc5..... J'habite a   Tema. Je parle anglais, fran  ais6..... Ga.

Je suis grand et7..... Mon pe  re8..... dans une usine a   Tema et9..... me  re est vendeuse. Elle vend10..... bananes au marche  .

	A	B	C	D
1.	appelles	appellent	appeler	appelle
2.	suis	ai	a	es
3.	es	suis	��tais	est
4.	viens	vient	viennent	venir
5.	ghane����en ghane��ennes	ghane��enne	ghane��ens	
6.	mais	avec	et	pour
7.	forte	fort	forts	fortes
8.	travailler	travailles	travaille	travaillent
9.	mon	ma	ses	mes
10.	la	des	mes	le

FRENCH

PAPER 2

Essay Writing - 45minutes (40marks)

Example 1 (Letter writing)

You are looking for a pen-pal. You have finally found the particulars of one in a magazine. Use the information you have found to write a letter to him/ her. The following outline will help you write your letter.

- votre adresse/date
- salutation
- dites où vous avez trouvé son adresse
- dites pourquoi vous l'écrivez
- présentez-vous
- identité
- goûts
- votre famille
- demandez deux informations supplémentaires le/ la concernant
- conclusion
- votre prénom/nom.

Example 2 (Picture description)

Study the pictures numbered a – f and narrate the story by answering the questions asked on each of them.

Amina et son chat

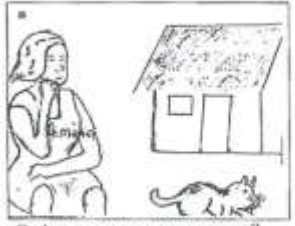

- Qu' est-ce que vous voyez?
- pourquoi Amina est-elle triste?

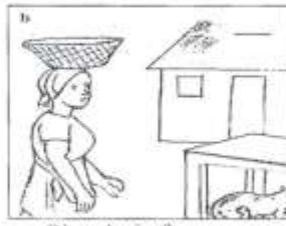

- Où va Amina?
- Où se trouve son chat?



- Qu' est-ce qu' Amina a sur la tête?



- Où est le chat?
- Ou' est-ce que le chat cherche?



- Où est le chat et que fait-il?
- Maintenant que fait Amina?



- Pourquoi Amina est elle fâchée?
- Qu' est-ce qu' elle fait?

GHANAIAN LANGUAGES AND CULTURE

SYLLABUS TOPICS

Customs and Institutions

- Greetings and Responses
- Naming Systems and Ceremonies
- Kinship Terms
- Annual Festivals
- The Clan System
- Commitment
- Puberty Rites
- Gratitude and Appreciation
- Taboos
- Death and Funeral Rites
- Marriage and Divorce
- Tradition: Chieftaincy and Governance
- Traditional Judicial Procedures
- Traditional Costumes
- Contemporary Social Problems

Oral and Written Literature

- Introduction to Literature
- Characteristics of Oral Literature
- Characteristics of Written Literature
- Proverbs
- Non-Verbal Communication: Body Language
- Symbols and their Meanings
- Riddles and Puzzles
- Folktales
- Work songs and Play songs
- Dirges

Essay Writing

- Narrative
- Descriptive (e.g. Giving Directions)
- Expository
- Argumentative
- Letter Writing

The essay should not be less than 150 words.

Comprehension

Prose passage which will be about 250 words, on (outline concepts and types of passages).

Lexis and Structure

Vocabulary

- Idioms and Idiomatic Expressions
- Synonyms
- Antonyms

Structures

- Parts of Speech: Nouns, Pronouns, Verbs, Adverbs, Adjectives, Conjunctions, Emphatic Particles, Determiners and Post Positions.
- Punctuation
- Linkers
- Prefixes and Suffixes
- Sentence Structure - Identification of Phrases, Clauses, Subjects, Objects.

STRUCTURE AND SCHEME OF THE EXAMINATION

There will be Paper 1 and 2, both of which must be taken. The Papers will be combined and taken at one sitting.

Paper 1: Paper 1 will consist of 40 multiple choice objective test questions on customs and institutions, oral and written literature, of the particular language. Candidates will be required to answer all questions within 45 minutes for 40 marks.

Paper 2: This will consist of three (3) parts as follows:

Part I – Essay:

Four (4) questions will be set and candidates will be required to answer only one for 30 marks.

Part II – Comprehension:

Ten (10) questions will be set. Candidates will be required to answer all the questions for 10 marks.

Part III – Lexis and Structure:

Twenty (20) questions on Sentence Composition and either multiple choice objective **or** completion type questions will be set for candidates to answer all for 20 marks.

The paper will last one (1) hour and will carry 60 marks.

Weighting of the Papers

Paper	Total Marks	Scaling Factor	Total
1 (Objective)	40	1	100
2 (Essay)	60	1	

SAMPLE QUESTIONS PAPER 1

PART - SAMPLE PASSAGE

PAPER 2:

Part 1 - Essay

Part II: COMPREHENSION (10 marks)

Read this passage and answer all the questions.

A long time ago Crab was a very handsome man. He was tall and had fine hair. He was also very kind. He had many friends amongst whom were Scorpion, Lobster, Snail and Spider.

One day, Spider went to Crab. He said, “Crab, I’m in trouble. I must go to the Chief’s house now. I must think and speak well to the Chief. Give me your head so that I can think and speak well.”

Crab said, “My good friend, I’m sad that you are in trouble. You can have my head so that you can think well and speak well to the Chief.” Crab gave his head to Spider. Spider put Crab’s head on his head. Then he went to the Chief’s house.

The Chief was very angry to see him. He said, “Spider, you are a bad man. You stole my gold. Because of this, we are going to cut of your head. Now, soldiers, cut off his head!” The soldiers cut off Spider’s head at once. But it was Crab’s head. Spider went away and nobody saw him again.

Crab waited and waited but Spider did not come back. Crab was always inside his hole. He could not go out. He could neither see, hear nor eat because he had no head. God was sad that Crab had no head. God gave Crab a shell to cover his body. He gave Crab eight small legs and two big ones. The big ones were his claws. He used the claws to nip people who would trouble him.

- (a) Long ago, what was the appearance of Crab?
- (b) Who were the friends of Crab?
- (c) Which of these friends was in trouble?
- (d) Why was the Chief angry with Spider?

GHANAIAN LANGUAGES AND CULTURE

- (e) Why was it necessary for Spider to speak well at the Chief's house?
- (f) What was the importance of the punishment meted out to Spider?
- (g) Why did Spider refuse to go back to inform Crab about the loss of his head?
- (h) Give the antonym of "kind".
- (i) What part of speech is 'shell'?
- (j) Give a suitable title to the passage.

SOCIAL STUDIES

SYLLABUS TOPICS

The Environment

- The Environment and Environmental Problems
- Adolescent reproductive health
- Our Culture
- Mapping our environment
- Ghana, My country
- Natural features of the earth
- Population growth and development in Ghana

Governance, Politics and Stability

- Ghana as a nation
- Colonization and national development
- Independence and nationhood
- Citizenship and human rights
- Our constitution
- Law and order in our constitution
- Meaning and prevention of conflicts
- Ghana's cooperation with other nations
- Government and society
- Promoting Political stability in Ghana

SOCIAL AND ECONOMIC DEVELOPMENT

- The use of land in our community
- Our Natural and Human Resources
- Production in Ghana
- Managing your finance
- Tourism, Leisure and Development
- Education and Productivity
- Entrepreneurship
- Problems of development in Ghana
- Sustainable national development
- The youth and discipline

STRUCTURE AND SCHEME OF EXAMINATION

The will be two papers, Papers 1 and 2 both of which must be taken. The Papers will be combined and taken at one sitting.

Paper 1 will consist of 40 objective questions, all of which must be answered in 45 minutes for a total of 40 marks.

Paper 2 will be an essay-type paper consisting of **three** sections, A, B and C thus **Two** questions will be set on each section, and as follows:

Section A: The Environment

Section B: Governance, Politics and Stability

Section C: Social and Economic Development.

Candidates will be required to answer **three** questions in all choosing **one** question from each section. The paper will last 1 hour and carry 60 marks.

SAMPLE QUESTIONS

PAPER 1 OBJECTIVE

1. Which of the following conditions cannot be described as an effect of irresponsible adolescent behaviour?
 - A. Becoming an outcast in society
 - B. Becoming a drug addict
 - C. Dropping out of school
 - D. Receiving commendation from elders
2. Human interaction is specifically part of the
 - A. artificial environment.
 - B. natural environment.
 - C. physical environment.
 - D. social environment
3. Female genital mutilation should be abolished because it
 - A. makes girls infertile.
 - B. makes girls very ugly.
 - C. promotes prostitution.
 - D. violate the rights of the girls.
4. Which of the following factors can create political instability in Ghana?
 - A. A workable constitution
 - B. Free and fair elections
 - C. Rigging of election
 - D. Rule of law
5. The production of goods and services can be increased in Ghana through
 - A. increment in salaries of workers
 - B. long period of service.
 - C. the acquisition of higher education.
 - D. the application of appropriate technology
6. Which of the following conditions can result in indiscipline among the youth in Ghana?
 - A. Good employment
 - B. Parental guide
 - C. Quality education
 - D. Substance abuse

PAPER 2

ESSAY

SECTION A
THE ENVIRONMENT

1. (a) State four benefits of staying chaste. [4 marks]
(b) Outline four effects of irresponsible adolescent behaviour. [16 marks]

SECTION B
GOVERNANCE POLITICS AND STABILITY

2. (a) What is co-operation? [4 marks]
(b) Highlight four benefits Ghana derives from cooperating with other nations. [16 marks]

SECTION C
SOCIAL AND ECONOMIC DEVELOPMENT

3. Explain five reasons why an individual should save towards the future. [20 marks]

RELIGIOUS AND MORAL EDUCATION

SYLLABUS TOPICS

RELIGION

- God, creation and His attributes.
- Religious Practices and their moral implications.
- Religious Personalities
- Religious Festivals
- Rites of Passage

Moral Life

- Manners
- Chastity and morality
- Moral teachings and commitment
- Reward and Punishment
- Decency and substance abuse

Social Life

- The family system
- Obedience
- Religious home and neighbourhood
- Work
- Money
- Time and Leisure
- Religious Youth Organizations

STRUCTURE AND SCHEME OF EXAMINATION

There will be two papers: Paper 1 and Paper 2 both of which must be taken. The papers will be combined and taken at one sitting.

PAPER 1: This will consist of 40 multiple choice (objective) test, of 45 minutes duration, and candidates will be required to attempt all the questions.

PAPER 2: This will be an essay paper consisting of three Sections A, B and C. Three questions will be set in each of Sections A and B and two questions in Section C as follows:

SECTION A: RELIGION

This will consist of **three** essay type questions on religion and candidates will be required to attempt only **one** of the questions.

SECTION B: MORAL LIFE

This will consist of **three** essay-type questions on moral life and candidates will be required to attempt only **one** of the questions.

SECTION C: SOCIAL LIFE

This will consist of **two** essay-type questions on social life and candidates will be required to attempt only **one** of the questions.

The Paper will last 1 hour and carry a total of 60 marks.

SAMPLE QUESTIONS

PAPER 1 (OBJECTIVE)

1. The first book in the Bible is
 - A. Deuteronomy.
 - B. Exodus.
 - C. Genesis.
 - D. Revelation.

2. Which of the following is a traditional puberty rite?
 - A. Akwambo
 - B. Damba
 - C. Dipo
 - D. Fetu

3. A Muslim must offer prayers
 - A. four times daily.
 - B. five times daily.
 - C. six times daily.
 - D. seven times daily.

4. Which of the following people was **not** a disciple of Jesus?
 - A. James
 - B. Mathew
 - C. Paul
 - D. Peter

5. The first thing to do when you enter a house is to
 - A. offer prayers.
 - B. identify yourself.
 - C. offer greetings.
 - D. locate the landlord.

6. Which of the following is **not** a duty of a child?
 - A. Preparing meals
 - B. Paying bills
 - C. Sweeping the compound
 - D. Fetching water

7. The nuclear family consists of father, mother and
 - A. aunties.
 - B. cousins.

- C. children.
 - D. grandparents.
8. In order to live in harmony with members of our community, we must be
- A. brave.
 - B. corrupt.
 - C. greedy.
 - D. obedient.
9. A major source of conflict among members of a community is through
- A. creativity.
 - B. laziness.
 - C. hardwork.
 - D. misunderstanding.
10. A person is said to be tolerant when the person is
- A. kind.
 - B. patient.
 - C. responsible

PAPER 2(ESSAY)

SECTION A

RELIGION

1. (a) Narrate the story of creation in the Bible.
- (b) State **two** attributes of God that can be learnt from the story.

SECTION B

MORAL LIFE

2. (a) Identify **five** examples of bad deeds.
- (b) Explain **four** types of punishment.

SECTION C

SOCIAL LIFE

3. (a) List **four** types of work.
- (b) Outline **four** ways by which a student can develop the spirit of hard work.

INTEGRATED SCIENCE

SYLLABUS TOPICS

DIVERSITY OF MATTER

- Introduction of Integrated Science
- General characteristics of matter
- Plants and Animals
- Measurement
- Density
- Soil
- Hazards
- Elements, Compounds and Mixtures
- Chemical compounds
- Metals and Non-Metals
- Acids, Bases and Salts
- Mixtures
- Water

B. CYCLES

- Flowering Plants
- Vegetative Crop Production
- Animal Production
- Fish Culture
- Carbon Cycle
- Climate
- Life Cycle of a Mosquito

C. SYSTEMS

- Respiratory Systems of Humans
- Farming Systems
- Reproduction and Growth In Humans
- Heredity
- Diffusion and Osmosis
- Circulatory System in Humans
- The Solar System
- Dentition in Humans
- Digestion in Animals

D. ENERGY

- Sources and Forms of Energy
- Basic Electronics
- Light
- Electrical Energy
- Heat
- Photosynthesis
- Food and Nutrition

E. INTERACTIONS OF MATTER

- Ecosystem
- Physical and Chemical changes
- Infections and Diseases
- Pests and Parasites
- Force and Pressure
- Machines
- Magnetism
- Technology and Development
- Machinery
- Entrepreneurship

STRUCTURE AND SCHEME OF EXAMINATION

There will be two papers: Papers 1 and 2, both of which must be taken. The two Papers will be combined and taken at one sitting.

Paper 1: will be a multiple-choice objective paper made up of 40 questions drawn from the entire syllabus. All the questions must be answered in 45 minutes for 40 marks.

Paper 2: shall be an essay paper made up of two parts, I and II to be answered in 1 hour 15 minutes.

Part 1: will be one compulsory question consisting of four sub-questions testing in practical skills specified in the Physics, Chemistry, Biology and Agriculture aspects of the teaching syllabus. Part I will attract 40 marks.

Part II: will consist of five essay questions. Each question shall be a blend of two or more closely related themes. Candidates will be required to answer any four questions for 60 marks.

1. SAMPLE QUESTIONS

OBJECTIVES

1. Tapeworm is classified as a/an
 - A. endoparasite.
 - B. ectoparasite.
 - C. pest.
 - D. vector.

2. Cultivation of perennial crops is done under
 - A. aquaculture.
 - B. alley cropping.
 - C. monoculture.
 - D. mixed cropping.

3. Which of the following diseases infects **both** farm animals and humans?
 - A. Anthrax
 - B. Burulli ulcer
 - C. Coccidiosis
 - D. Typhoid

4. 20g of fresh soil weigh 15g after drying. Determine the percentage moisture content of the soil.
 - A. 75%
 - B. 50%
 - C. 25%
 - D. 20%

5. Yellowing of the older leaves of growing plants is a sign of deficiency of
 - A. calcium.
 - B. nitrogen.
 - C. phosphorus.
 - D. potassium.

6. Which of the following farming systems is practiced in communities where land is scarce?
 - A. Land rotation
 - B. Crop rotation
 - C. Ecological farming
 - D. Mixed farming

7. Which of the following nursery practices ensures the production of uniform seedlings?
 - A. Shading
 - B. Pricking out
 - C. Soil stirring
 - D. Watering

8. In agribusiness, retailers operate within the
- A. production chain.
 - B. processing chain.
 - C. supply chain.
 - D. value chain.
9. Turbidity of pond water can be controlled through
- A. de-silting.
 - B. fertilization.
 - C. harvesting.
 - D. liming.
10. The processes of osmosis and diffusion are carried out in living cells through the
- A. mitochondria and nucleus.
 - B. chloroplast and nucleus.
 - C. selective membranes and nucleus.
 - D. chloroplast and mitochondria.
11. Which blood vessel carries oxygenated blood from the lungs to the heart?
- A. Pulmonary artery
 - B. Pulmonary vein
 - C. Jugular vein
 - D. Aorta
12. The density of water is 1g/cm^3 . Which of the following substances will float in water?
A material of mass
- A. 12g and volume 10cm^3
 - B. 22g and volume 20cm^3
 - C. 30g and volume 28cm^3
 - D. 12g and volume 13cm^3
13. A bee sting is known to be acidic. Which of the following chemical substances can be used to treat bee stings?
- A. Common salt
 - B. Lime juice
 - C. Ripe orange juice
 - C. Ripe orange juice
 - D. Wood ash
14. The process by which rocks break down to form soil is known as
- A. composting.
 - B. erosion.
 - C. leaching.
 - D. weathering.

15. Night blindness can be prevented by taking enough vitamin
- A. C.
 - B. D.
 - C. E.
 - D. K.

PAPER 2 (ESSAY)

(100 marks)

1 hour 15 minutes

PART 1 (Compulsory – 40 marks)

1. (a) In an experiment an iron bar is magnetized by dragging a magnet over the surface of the bar from end A to end B several times as shown the diagram below.

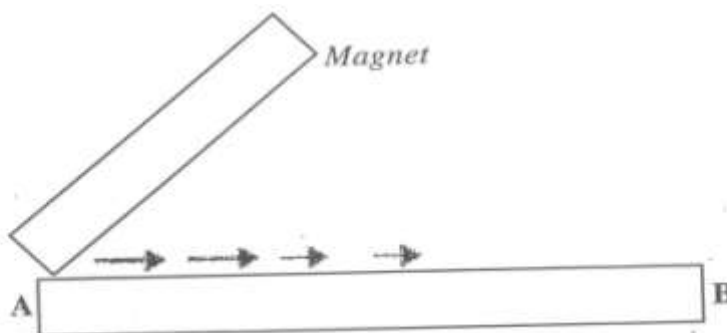

- (i) Mention the method of magnetization used.
 - (ii) State the polarity of the end of the magnet used in the magnetization process, if the ends **A** and **B** of the bar become North Pole and South Pole, respectively.
 - (iii) How will you test that the bar **AB** has become a magnet?
 - (iv) Indicate how you will test for the poles **A** and **B** of the bar.
 - (v) Give one precaution that should be taken during the magnetization process.
 - (vi) Name one other method of magnetization.
- (b) The set-up below is used to prepare a gas in the laboratory.

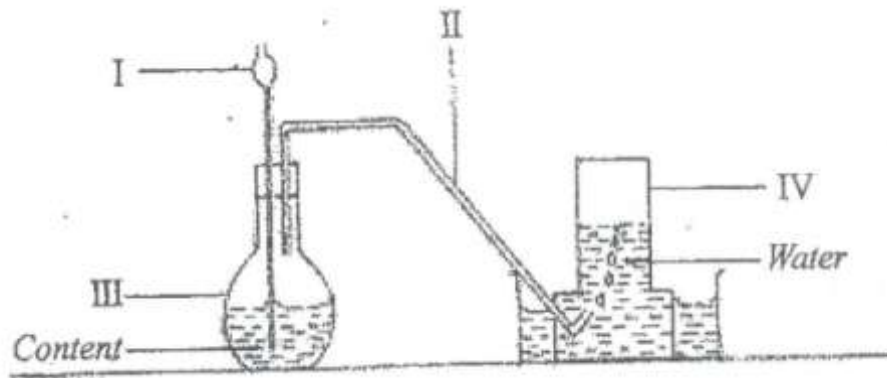

- (i) Give the names of the parts labeled **I**, **II**, **III** and **IV**.
- (ii) Write down the two names of the method of gas collection.
- (iii) Explain how the gas collects over the water.
- (iv) Name two gases that can be prepared using the set-up.

- (c) The set-up below shows air being breathed out through the mouth into a test tube containing lime water.

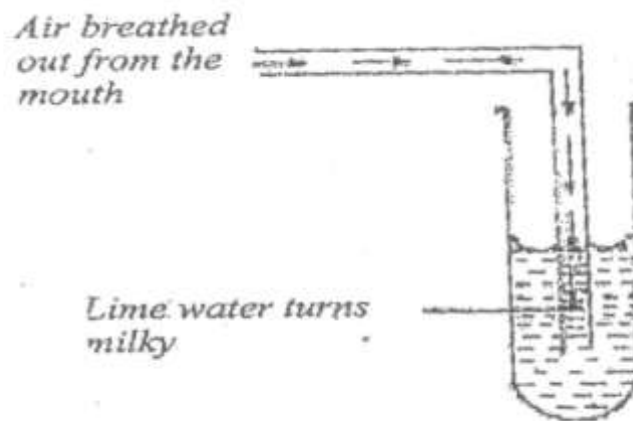

- (i) Why does the lime water turn milky?
- (ii) Identify the milky substance produced.
- (iii) Write a balanced chemical equation for the reaction in the test tube.
- (iv) Name two other substances present in the breathed-out air.
- (v) What is the aim of the experiment?

- (d) The diagram below shows the set-up used in a test on soil sample.

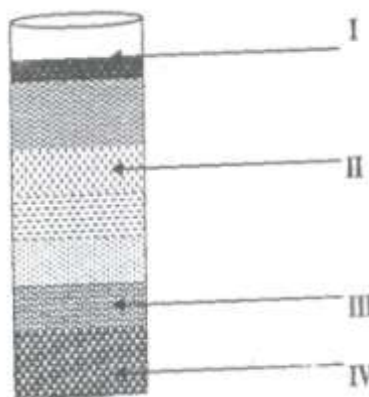

- (i) Name the parts labeled **I**, **II**, **III** and **IV**.

- (ii) Mention the property of soils that the experiment is testing.
- (iii) Give the steps of the experiment.
- (iv) State three functions that the soil component identified as **I** plays in crop production.

PART II
(60 marks)

*Answer any **four** of the following questions:*

- 2.**
- (a) What is a *living cell*?
 - (b) Give one function of the following components of a living cell:
 - (i) cell membrane;
 - (ii) chloroplast;
 - (iii) nucleus.
 - (c) Make sketches to show the arrangement of particles in **each** of the **three** states of matter.
 - (d) What instrument would you use to measure **each** of the following quantities:
 - (i) volume of a liquid;
 - (ii) mass of a stone;
 - (iii) time;
 - (iv) speed of the wind?
- 3.**
- (a) Name **three** deficiency diseases associated with diet and state their causes.
 - (b)
 - (i) What is *hard water*?
 - (ii) Mention three ways by which hard water can be made soft.
 - (c)
 - (i) Explain how sound is produced.
 - (ii) State one example each, of the following instruments:
 - (a) wind instrument;
 - (b) string instrument.
- 4.**
- (a) State **two** examples of a
 - (i) carnivore;
 - (ii) herbivore.
 - (b) What is the difference between *egestion* and *excretion*?
 - (c) Explain briefly why

- (i) gold is used to make necklaces and earrings.
 - (ii) steel is used instead of iron to make car bodies.
- (d)
- (i) What is surface tension?
 - (ii) Explain why the surface of water in a container is **not** flat but curved.

MATHEMATICS

SYLLABUS TOPICS

- Sets
- Operations on Sets
- Properties of Natural Numbers
- Numeration System
- Operations on Whole Numbers
- Positive and negative Integers, Rational Numbers
- Common Fractions and Decimal Fractions
- Ratio and Proportion
- Percentages, Rates and Taxes
- Exponents (Indices)
- Collecting and Handling Data (Statistics)
- Probability
- Algebraic Expressions
- Linear Equations in One Variable
- Linear Inequalities in One Variable
- Mapping
- Number Plane
- Basic Solids
- Length and Area of Plan Figures
- Volume of Basic Solids
- Angles
- Right-Angled Triangle (Properties)
- Measurement of Capacity, Mass, Time and Money
- Rigid Motion
- Enlargement and Similar figures
- Constructions, Loci
- Vectors
- Investigation with Numbers

SCHEME OF EXAMINATION

There will be two papers: Paper **1** and **2**, both of which must be taken. The Papers will be combined and taken at one sitting.

Paper 1: will be a multiple-choice objective paper consisting of **40** questions. The questions will be drawn from the entire syllabus and candidates will be expected to answer them within 1 hour for 40 marks.

Paper 2: will be an essay paper. It will consist of **six** questions and candidates will be expected to answer any **four** within 1 hour for 60 marks. Questions in this paper may be drawn from any part of the syllabus.

1. **SAMPLE QUESTIONS**

PAPER 1 (OBJECSTIVES)

1. How many subsets has the set $P = \{-1, 0, 2\}$?
- A. 8
B. 6
C. 4
D. 3
2. A man spends $\frac{1}{3}$ of his salary on his children's education and $\frac{2}{5}$ of the remainder on accommodation. What fraction of his salary is left?
- A. $\frac{5}{9}$
B. $\frac{3}{8}$
C. $\frac{2}{5}$
D. $\frac{3}{5}$
3. Evaluate $\frac{a}{b}$, if $a = \frac{1}{2}$ and $b = \frac{1}{4}$.
- A. 4
B. 3
C. 2
D. 1
4. Nana Yaa receives 20% commission on her weekly sales. In a week if she receives ₵800.00 as commission, calculate her total sales for the week.
- A. ₵1,200.00
B. ₵2,400.00
C. ₵3,200.00
D. ₵4,000.00
5. A basket contains 15 oranges and 25 mangoes. What is the probability of selecting a mango from the basket?
- A. $\frac{1}{15}$
B. $\frac{1}{25}$
C. $\frac{3}{8}$
D. $\frac{5}{8}$

6. Multiply 0.0012×0.02 leaving the answer in standard form.
- A. 2.4×10^5
 - B. 2.4×10^4
 - C. 2.4×10^{-4}
 - D. 2.4×10^{-5}
7. Write the compass bearing $S40^\circ E$ as a three figure bearing.
- A. 140°
 - B. 040°
 - C. 220°
 - D. 320°
8. If vector $b = \begin{bmatrix} 2 \\ 3 \end{bmatrix}$ and $2a - b = \begin{bmatrix} 6 \\ 7 \end{bmatrix}$, find vector a .
- A. $\begin{bmatrix} 4 \\ 5 \end{bmatrix}$
 - B. $\begin{bmatrix} 4 \\ 4 \end{bmatrix}$
 - C. $\begin{bmatrix} -4 \\ 5 \end{bmatrix}$
 - D. $\begin{bmatrix} 8 \\ 10 \end{bmatrix}$
9. What is the next term of the sequence 1, 2, 3, 5, 8.....?
- A. 10
 - B. 11
 - C. 12
 - D. 13
10. A rectangle has an area of 117cm^2 and a width of 9 cm. Find its length.
- A. 9 cm
 - B. 11 cm
 - C. 13 cm
 - D. 15 cm
11. The scale of a map is 1 : 10000. The distance between two points on the map is 4 cm. What is the actual distance between the points?
- A. 4 m
 - B. 40 m
 - C. 400 m
 - D. 4000 m

12. Which of the following expressions is illustrated on the number line below?

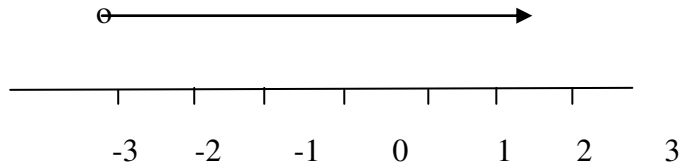

- A. $x < -3$
B. $x \leq -3$
C. $x > -3$
D. $x \geq -3$

PAPER 1 (ESSAY)

1. Of the 53 pupils of Kofikrom Junior High School, 36 take tea, 18 take coffee and 10 take neither tea nor coffee.

- (a) Draw a Venn diagram to illustrate this information.
(b) Using your diagram, determine the number that takes both tea and coffee.

2. Simplify $\frac{4a^2+8ab}{3} \div \frac{5ab+10b^2}{9}$

3. Three church bells start ringing at intervals of 5, 12 and 15 minutes respectively. If they ring together at 12.00 noon on a given day, when will they next ring together?

4. Copy and complete the magic square below so that the sum along the rows, columns and diagonal are the same and equal to 15.

4		
	5	7

5. The diagram below shows the farm of Mr. Mensah. After a heavy rainfall, part of the farm got flooded. The shaded portion represents the flooded part.

Calculate the area of the flooded part.

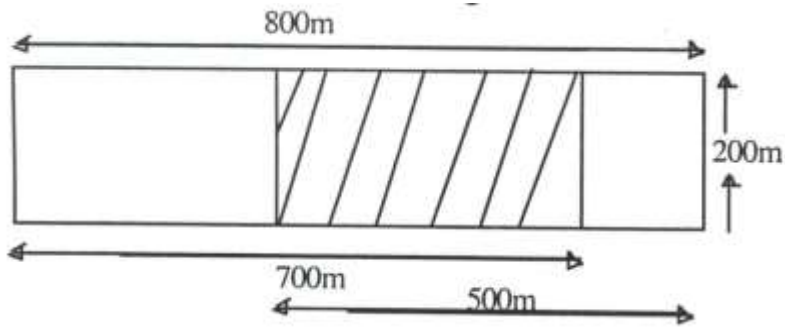

6. The table below shows the number of goals scored by a football team in a league season.

<i>No. of goals</i>	0	1	2	3	4	5
<i>Frequency</i>	1	7	6	4	1	1

- (a) Find the total number of goals scored by the team.
(b) What is the total number of matches played in the league season?
(c) Find the mean of the number of goals scored by the team.

BASIC DESIGN AND TECHNOLOGY

SYLLABUS TOPICS

MATERIALS

- Metals:
Ferrous and non-ferrous
- Timber
- Building materials
- Abrasives
- Adhesives
- Finishes
- Plastics

TOOLS

- Safety precautions
- Measuring tools
- Setting-out and marking out tools
- Cutting tools
- Holding tools
- Removing and driving tools
- Striking tools
- Digging tools
- Laying tools

PROCESSES

- Moulding bricks
- Walling
- Fastenings
- Sheet metal work

BASIC ELECTRICAL AND ELECTRONICS

- Basic Electrical circuits
- Basic Electronics circuits

TECHNICAL DRAWING

- Isometric Drawing
- Oblique Drawing
- Perspective Drawing
- Orthographic Projections
- Development of Prisms
- Development of Pyramids

SCHEME OF EXAMINATION

There will be two papers for each of the Basic Design and Technology options
Paper 1 will contain 30 multiple choice objective questions to be answered in 40 minutes for 30 marks Home Economics or Pre-Technical Skills, the Core skills syllabus will contribute 15 objective questions while the other 15 objective questions will come from either of the two options (Home Economics or Pre-Technical Skills) to make up paper 1.

However, candidates who offer Visual Art will have the following component making up Paper 1:

Core Skills will contribute 15 multiple choice objective questions. Visual Communication will contribute 10 multiple choice objective questions.

Additional five (5) objective questions will come from either of the four (4) optional areas.

Paper 2 will be a 1 hour 15 minutes paper consisting of four (4) questions for candidates to answer three (3) questions for 70 marks.

Pre-Technical Skills and Home Economics Papers will consist of two Sections, A and B.

Section A will be **one** compulsory question on Core Skills for 20 marks.

Section B will consist of **three (3)** questions from either Home Economics or Pre-Technical Skills and candidates will be required to answer any **two (2)** questions for 50 marks.

Visual Art Paper 2 will consist of two Sections: A and B.

Section A will be **two (2)** compulsory questions: one on Core Skills and other on Visual Communication for 45 marks.

Section B will be subdivided into four (4) parts:

Part I: Weaving and Stitching.

Part II: Modeling, Casting and Carving.

Part III: Construction and Assemblage.
Part IV: Fabric and Leather Decoration.

Each part will have **two (2)** questions and candidates will be required to answer **one (1)** question only from any part of their choice for 25 marks.

SAMPLE QUESTIONS

PAPER 1 (OBJECTIVES)

1. An example of direct business risks is
 - A. low quality control.
 - B. fire outbreak.
 - C. poor work attitudes.
 - D. wrong location.

2. The fire aggregate in concrete mixture is
 - A. sand.
 - B. cement.
 - C. water.
 - D. stone.

3. The folding bar is used for
 - A. measuring.
 - B. cutting.
 - C. removing.
 - D. holding.

4. Which of the following is not a design principle?
 - A. Unity.
 - B. Harmony.
 - C. Texture.
 - D. Balance.

5. The tint of a hue is obtained by mixing with
 - A. blue.
 - B. white.
 - C. black.
 - D. red.

6. In perspective drawing, near objective appear to be
 - A. small.
 - B. light.
 - C. big.
 - D. short.

7. Which of these statements described a menu?
 - A. Collection of prepared dishes eaten at a sitting.
 - B. Prepared item of food.
 - C. List of dishes with their prices.
 - D. Specially prepared dish for a specific function

8. The importance of table laying is that it
 - A. enable one to eat more slowly and quality.
 - B. makes eating more pleasant.
 - C. enable one to be on time for males.
 - D. it makes one learn to use cutlery properly.

9. Soup is served as

- A. an accompaniment.
 - B. a main meal.
 - C. a starter to meal.
 - D. a replacement of water.
10. In Ghana, blue symbolizes
- A. victory.
 - B. sadness.
 - C. peace.
 - D. richness.

PAPER 2 (ESSAY)

1. (a) (i) List the **three (3)** classes of food and give an example of **each**.
 (ii) State **two (2)** major functions of protein.
 - (b) (i) Explain **three** deficiency signs of Vitamin C
 (ii) Explain **three** functions of food to the human body.
 - (c) (i) State **four** causes of food spoilage.
2. (a) State **three** factors one should consider when selecting fresh fish for stewing.
 - (b) List four important factors that should be taken into consideration when planning meals for a sick child.
 - (c) Plan the day's **main** meals for a twelve-year old school child.
 - (d) List **six** items which would be needed in setting a table for lunch.

PRE-TECHNICAL SKILLS - OPTION

1. (a) (i) Make a freehand sketch of a centre punch.
 (ii) Indicate the point angle on the sketch in (i).
- (b) Figure 1 shows the front view and plan of a cylinder made from a 0.5mm aluminium sheet.

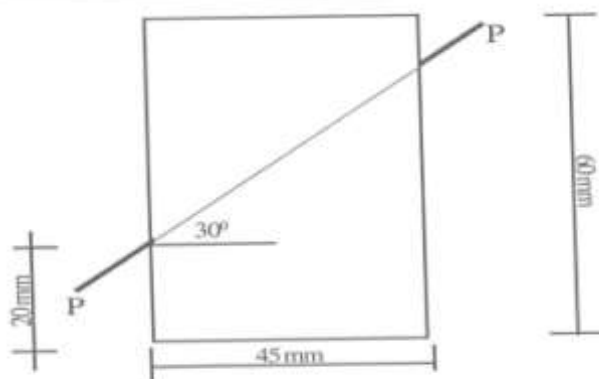

Fig. 1

- (i) Draw the surface development of the cylinder.
 - (ii) State **one** suitable tool for cutting the sheet metal.
 - (iii) State **two** properties of aluminium.
- (c) Draw a circuit diagram showing a battery, a bulb and a switch in series.

VISUAL COMMUNICATION OPTION

1. (a) Describe **three** ways of finishing lettering on a poster.
- (i)
 - (ii)
 - (iii)

- (b) (i) Draw **three** cubes in the boxes provided below.

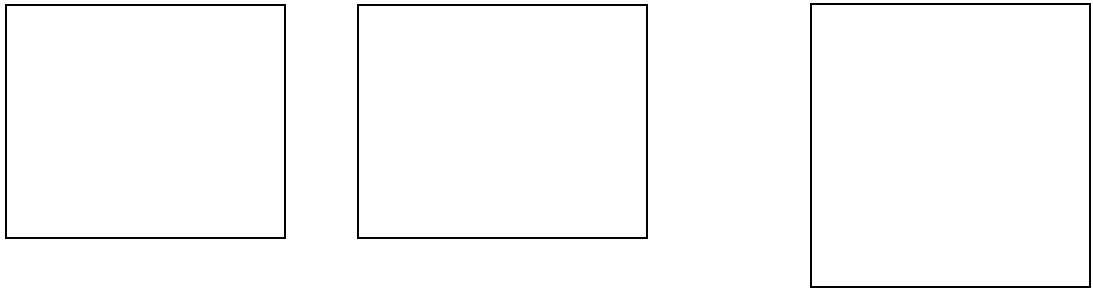

- (ii) Use a different method of shading in each portion. Name the shading method used in each.

- (c) Name **three** materials used for making photomontage and explain how they are used.

- (i)
- (ii)
- (iv)

2. Using comps, illustrate the following text layout in the space provided.

(i) *Flush left*

A rectangular box with a thin black border, intended for illustrating the 'Flush left' text layout. The box is empty.

(ii) *Centered layout*

A rectangular box with a thin black border, intended for illustrating the 'Centered layout' text layout. The box is empty.

(iii) *Justifies*

A rectangular box with a thin black border, intended for illustrating the 'Justifies' text layout. The box is empty.

INFORMATION AND COMMUNICATION TECHNOLOGY

SYLLABUS TOPICS

- Parts of a Personal Computer
- Basic Input and Output Devices
- Basic Storage Media
- Switching on/off the Personal Computer
- Graphical User Interface
- File and Folder Management
- Information Processing Cycle
- Health And Safety in Using ICT Tools
- Ethics In Using ICT Tools
- Integration of ICT into Education
- Basic Typing Skills Development
- Review of Mouse Skills
- Creating Word Processing Document
- Editing a Word Processing Document
- Formatting Text in Word Processing Document
- Toolbars
- The Use of Drawing Toolbar in Word Processing Document
- Inserting Pictures in a Word Processing Document
- Printing a Word Processing Document
- Creating a Word Processing Document
- Creating a File in Paint Application
- Internet and World Wide Web
- Tools Used to Access the Internet
- Using the Internet to Communicate
- Accessing and Sharing Information
- Search Engines
- Introduction to Spreadsheet Application

SCHEME OF EXAMINATION

There will be **two** papers, Paper 1 and Paper 2, both of which must be taken. Papers 1 and 2 will be combined and taken at one sitting.

Paper 1 will comprise 40 compulsory multiple-choice objective questions and will last 45 minutes for 40 marks.

Paper **2 (essay)** will consist of **two** sections: **A** and **B**.

Section A will be a compulsory question for 24 marks and Section B will contain 4 questions out of which candidates will answer any 3 for 12 marks each. The Paper will last 1 hour 15 minutes and will carry a total of 60 marks.

SAMPLE QUESTIONS

PAPER 1 (OBJECTIVES)

1. The part of a computer system that performs arithmetic and logic operations on data is known as
 - A. visual display unit.
 - B. central processing unit.
 - C. input/output device.
 - D. memory storage device.

2. In the classification of computers, Personal computers (PC), Laptops, Notebooks and Personal digital assistants (PDA) are examples of
 - A. super computers.
 - B. micro computers.
 - C. mainframe computers.
 - D. mini computers.

3. An internal permanent store of memory which can be read but cannot normally be changed is the
 - A. ALU.
 - B. CAD.
 - C. RAM.
 - D. ROM.

4. The cursor which indicates the point at which a text should be marked is found on the
 - A. printer.
 - B. central processing unit.
 - C. visual display unit.
 - D. keyboard.

5. The most common unit of computer storage is the
 - A. bit.
 - B. byte.
 - C. bundle.
 - D. Buffer

PAPER 2 (ESSAY)

1. (a) Study the diagram below carefully and answer the questions that follow:

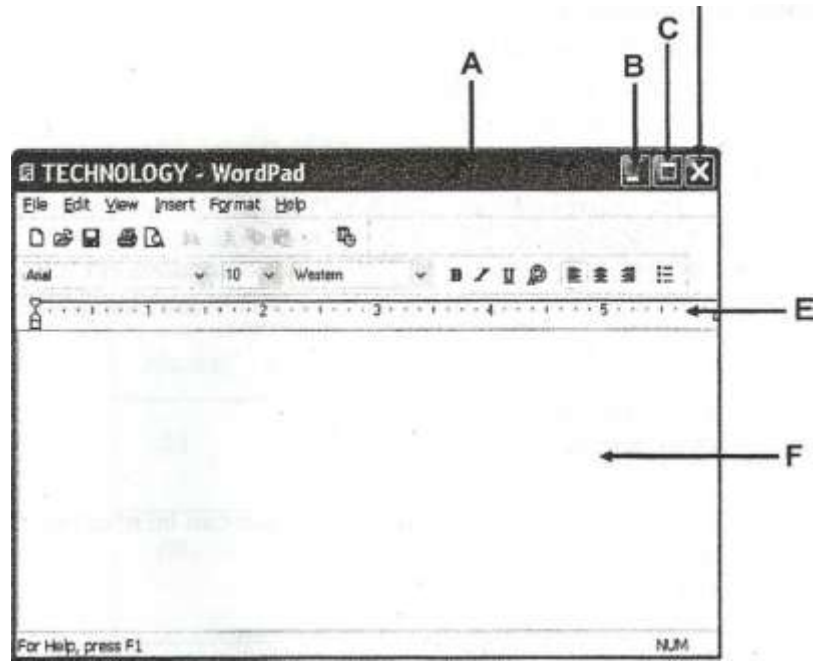

- (b) Use the spaces below to name the parts labelled above

A

B

C

D

E

F

[6 marks]

- (c) State one function for each of the following labelled parts?

B

C

D [3 marks]

Name the Application software used to create the document

..... [1 mark]

(d) Name the document created.

..... [2marks]

(e) Name three toolbars shown in the document window.

.....

.....

..... [3 marks]